

# 11-MD114

---

**Version** : A.006  
**Issue Date** : 2008-12-26  
**File Name** : SP-MD114-A.006.doc  
**Total Page** : 12

## *Motor Driver for Mobile Phone*



新竹市展業一路9號7樓之1

SILICON TOUCH TECHNOLOGY INC.

9-4F-3, Prosperity Rd I, Science-Based Industrial Park

Hsinchu, Taiwan, R.O.C.

Tel : 886-3-5727171 Fax : 886-3-5727390

---

---

## 11-MD114

### *Motor Driver For Mobile Phone*

#### General Specifications

The 11-MD114 is a 1.5 channel with low current consumption, low saturation voltage type bi-directional motor driver IC. It contains 1.5 CH constant current control that is optimal for use in M-shutter and Iris. Its miniature package supports reduced -space mounting in camera mobile phone and other portable device.

#### Features and Benefits

- Low voltage operation
- Low saturation voltage
- Low input current
- 1.5 CH constant current control
- Thermal shutdown protection
- Flexibility power using
- Thin, highly reliable package : WLCSP(0.79\*1.59\*0.5), DFN-10(3\*3\*0.75)

#### Pin Assignment

##### Pin Assignment of DFN10

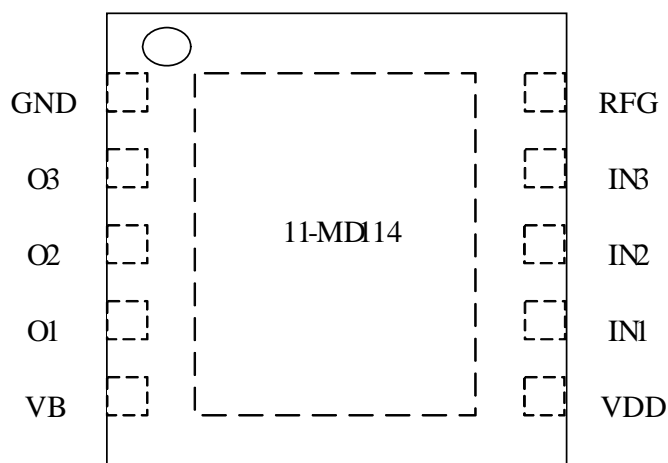

## Pin Descriptions

### Pin Assignment of DFN10

Pin NO.	Pin Name	Description
1	GND	Controller And Driver ground
2	O3	Motor output pin
3	O2	Motor output pin
4	O1	Motor output pin
5	VB	Power supply pin for motor driver
6	VDD	Power supply pin for controller.
7	IN1	Motor control input pin
8	IN2	Motor control input pin
9	IN3	Motor control input pin
10	RFG	Current sense resistor

### Pin Assignment of WLCSP (0.79\*1.59\*0.5mm)

#### TOP View

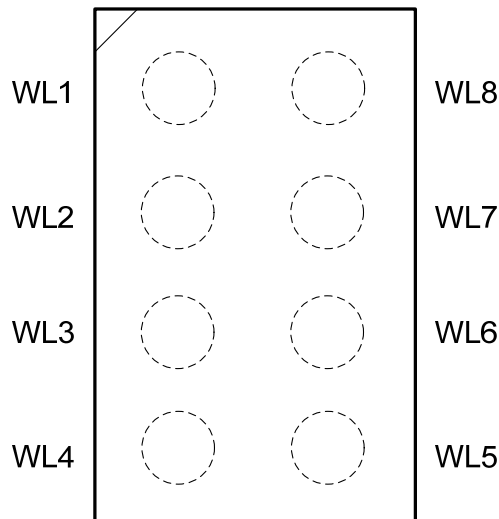

Pin NO.	Pin Name	Description
WL1	VDD	Power supply pin for motor driver and controller
WL2	O1	Motor output pin
WL3	O2	Motor output pin
WL4	O3	Motor output pin
WL5	VSS	Controller and Driver GND
WL6	IN3	Motor control input pin
WL7	IN2	Motor control input pin
WL8	IN1	Motor control input pin



### Absolute Maximum Ratings ( Unless otherwise noted, $T_A = 25^\circ\text{C}$ )

Characteristic	Symbol	Rating	Unit
Supply Voltage	$V_{DD}$	5.5	V
	$V_B$	5.5	V
Input Voltage	$V_{IN}$	$V_{DD}+0.4$	V
$I_O$ Peak Current	$I_{OPeak}$	1	A
$I_{ODC}$ Current	$I_{ODC}$	0.4	A
Power Dissipation	$P_D$	450	mW
Operating Temperature Range	$T_{OPR}$	-40 ~ 125	$^\circ\text{C}$
Storage Temperature Range	$T_{STG}$	-65 ~ 150	$^\circ\text{C}$

### Electrical Characteristic

(Unless otherwise noted,  $T_A = 25^\circ\text{C}$  &  $V_{DD} = V_B = 3\text{V}$ )

DFN10						
Characteristic	Sym.	Condition	Limit			Unit
			Min.	Typ.	Max.	
Supply Voltage	$V_{DD}$		1.75	3	5.5	V
	$V_B$				5.5	V
Supply Current ( $I_{DD}$ )	$I_{STB1}$	IN1=IN2=IN3=L		0.1	5	$\mu\text{A}$
	$I_{STB2}$	IN1=H, IN2=IN3=L		0.3	0.45	mA
	$I_{ACT}$	IN2, IN3 $\neq$ L		0.4	0.6	mA
Reference Voltage						
Reference Voltage	$V_{RFG}$		0.19	0.2	0.21	V
IN1, IN2, IN3 Input Terminal ( $T_J = 25^\circ\text{C}$ )						
Input Voltage "H"	$V_{IH}$	-	$0.8 \cdot V_{DD}$	-	$V_{DD}+0.4$	V
Input Voltage "L"	$V_{IL}$	-	-0.4	-	$0.2 \cdot V_{DD}$	V
Input Current "H"	$I_{IH}$	$V_{IN} = V_{DD}$	-	-	0.1	$\mu\text{A}$
Input Current "L"	$I_{IL}$	$V_{IN} = 0\text{V}$	-	-	0.1	$\mu\text{A}$
Output Terminal (O1, O2, O3)						
Output Voltage (upper + lower)	$V_{OUT}$	$I_{OUT} = 200\text{mA}$		0.3	0.45	V
Thermal Protection Circuit						
Protection Temperature	$T_{TSD}$	IN1=H, IN2, IN3 $\neq$ L		160		$^\circ\text{C}$

WLCSP						
Characteristic	Sym.	Condition	Limit			Unit
			Min.	Typ.	Max.	
Supply Voltage	$V_{DD}$		1.75	3	5.5	V
Supply Current ( $I_{DD}$ )	$I_{STB1}$	IN1=IN2=IN3=L		0.1	5	$\mu A$
	$I_{STB2}$	IN1=H, IN2=IN3=L		0.3	0.45	mA
	$I_{ACT}$	IN2,IN3 $\neq$ L		0.4	0.6	mA
Constant Output Current						
$I_{OUT}$	$I_{OUT}$	IN2,IN3 $\neq$ L	190	200	210	mA
IN1,IN2,IN3 Input Terminal ( $T_J = 25^\circ C$ )						
Input Voltage "H"	$V_{IH}$	-	$0.52 \cdot V_{DD}$	-	$V_{DD} + 0.4$	V
Input Voltage "L"	$V_{IL}$	-	-0.4	-	$0.2 \cdot V_{DD}$	V
Input Current "H"	$I_{IH}$	$V_{IN} = V_{DD}$	-	-	0.1	$\mu A$
Input Current "L"	$I_{IL}$	$V_{IN} = 0 V$	-	-	0.1	$\mu A$
Output Terminal (O1,O2,O3)						
Voltage Drop (Upper + Lower+ Sense Resistor)	$V_{OUT}$	$I_{OUT} = 200 mA$		0.5	0.6	V
Thermal Protection Circuit						
Protection Temperature	$T_{TSD}$	IN1=H, IN2, IN3 $\neq$ L		160		$^\circ C$



### Truth Table

INPUT			OUPUT			MODE
IN1	IN2	IN3	O1	O2	O3	
L	L	L	-*	-	-	STANDBY1
L	L	H	L	H	-	O2→O1
L	H	L	H	L	-	O1→O2
L	H	H	H	H	-	O1,O2 Break
H	L	L	-	-	-	STANDBY2
H	L	H	-	L	H	O3→O2
H	H	L	-	H	L	O2→O3
H	H	H	-	H	H	O2,O3 Break

\* : — : High Impedance

### Function Block

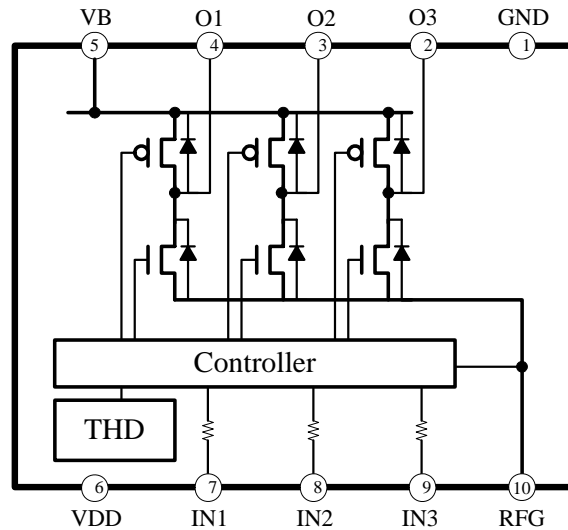

### Application Circuit: (DFN10)

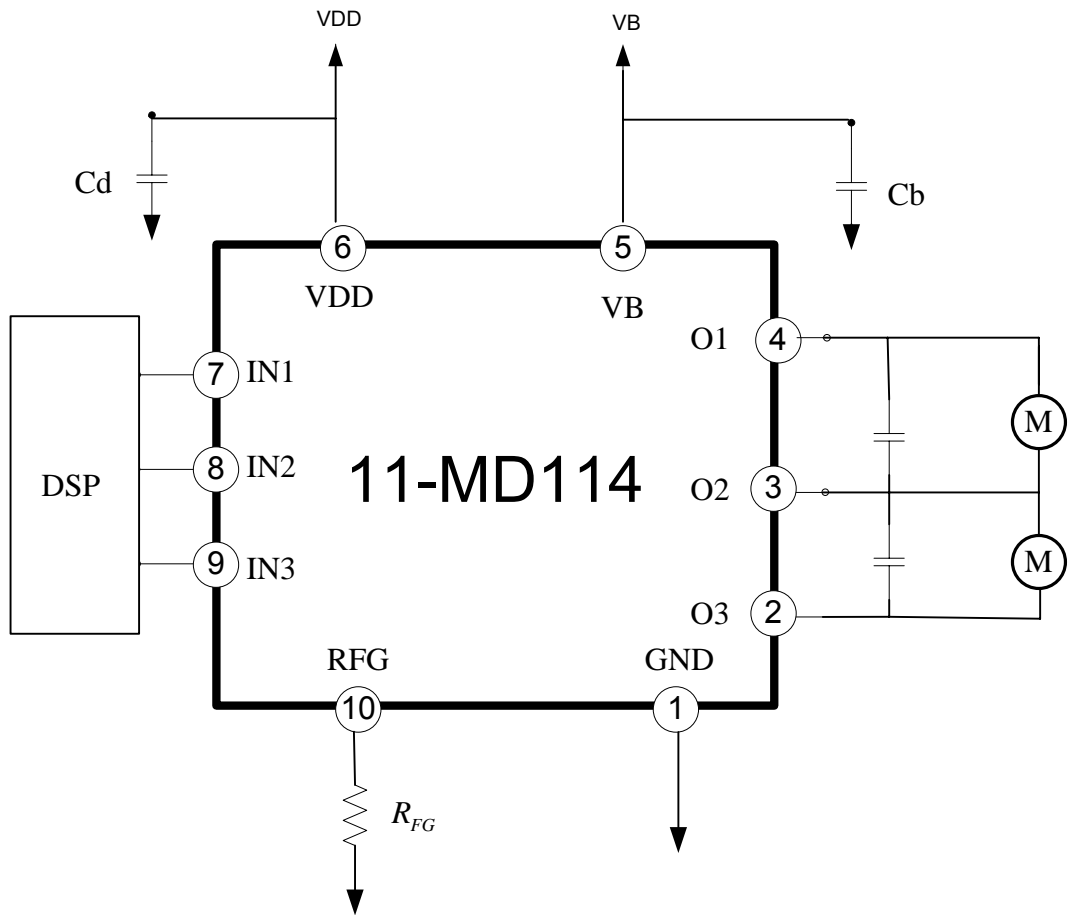

Note: 1.  $C_D$  and  $C_B$  are closed to IC.

2. Driver constant current  $I = \frac{0.2}{R_{FG}(\Omega)}$  (unit : A)

## Application Circuit: (WLCSP)

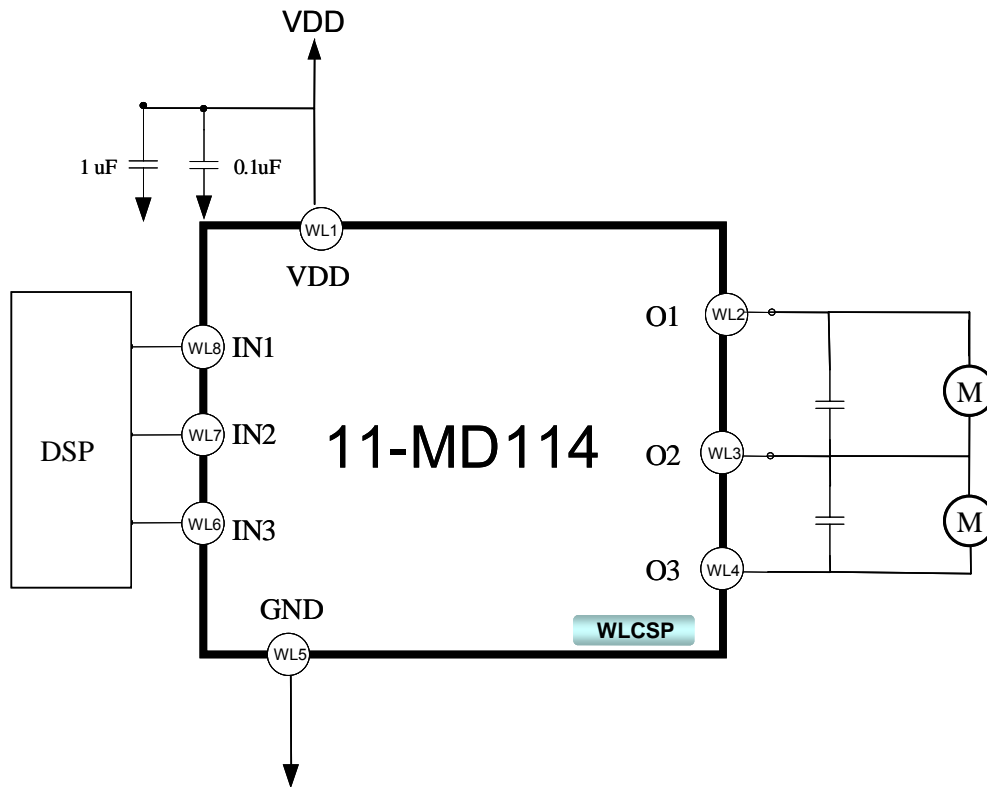

Note:  $R_{FG}$  (1ohm) is built inside.

## Application Notes

- The 11-MD114 is 1.5 CH constant current driver for use in M-shutter and Iris. The range of one supply voltage of 11-MD114, VDD is from 1.75V to 5.5V, and the other supply voltage of 11-MD114, VB, its maximum rating voltage can reach to 5.5V. The 11-MD114 input range is defined that logic "H" is from  $0.8 \cdot VDD$  to  $VDD + 0.4V$  and logic "L" is from  $-0.4V$  to  $0.2 \cdot VDD$ . The input pins, IN1, IN2, IN3, are motor rotation selection pins.



- Normally VB should provide enough current for output loading, thus large value of capacitor such as is suggested for the terminal VB. Besides, 0.01uF~0.1uF of capacitors are also suggested between each output channel and output channel to ground.
- The settling time from standby mode to output ready is about 10us. The main difference between STANDBY1 and STANDBY2 depends on voltage reference in the internal circuit is ready or not. In general, the rising time of constant current from the mode, STANDBY2, to the mode, O1 & O2 (or O2 & O3) should be faster than that of the mode, STANDBY1. However, the supply current  $I_{STB2}$  is larger than that of  $I_{STB1}$ , there is the tradeoff between the rising time and the amount of supply current.
- Constant current operation of 11-MD114 provides the current, which can be evaluated by the formula  $I = \frac{0.2}{R_{FG}} \text{ (A)}$ . It is obviously that constant current depends on the loading resistance of the terminal, RFG. Therefore, how to reduce the effect of line resistance from the terminal, RFG, to GND, will decide the accuracy of constant current.
- The power dissipated by the IC varies widely with the supply voltage, the output current, and loading. It is important to ensure the application does not exceed the allowable power dissipation of the IC package. The recommended motor driver power dissipation versus temperature is depicted as follows:

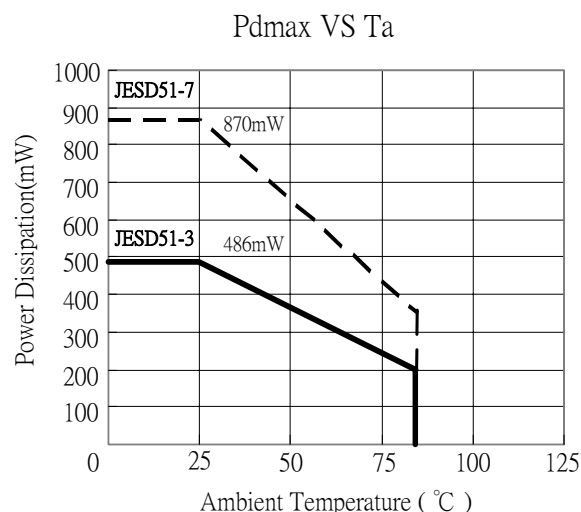



## Package Specification (DFN-10)

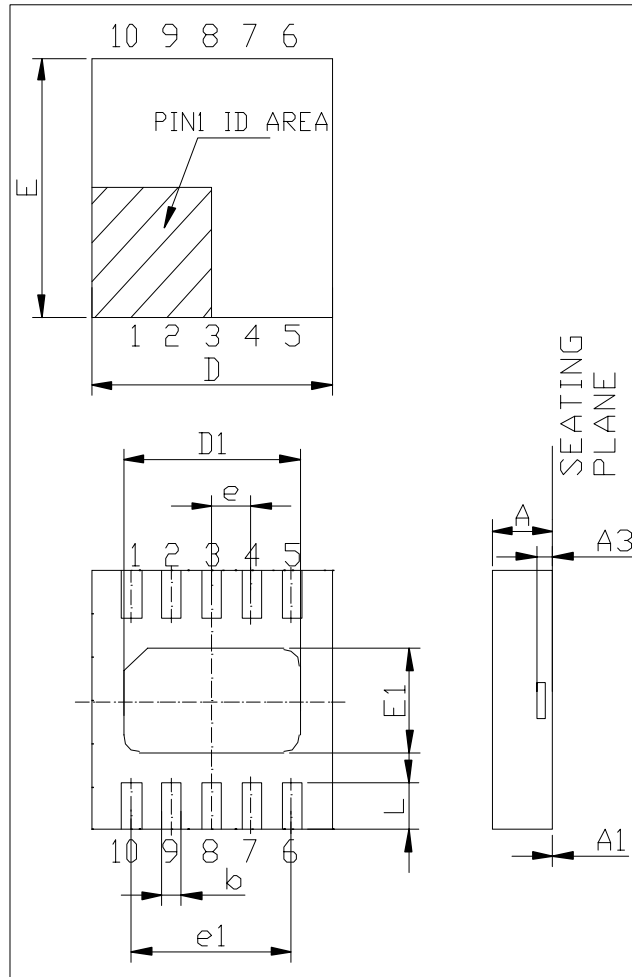

SYMBOL	DIMENSION (mm)			DIMENSION (mil)		
	MIN.	NOM.	MAX.	MIN.	NOM.	MAX.
A	0.70	0.75	0.80	28	30	32
A1	0.00	0.02	0.05	0	0.8	2
A3	0.203 REF			8 REF		
b	0.18	0.25	0.30	7	10	12
D	2.90	3.00	3.10	114	118	122
D1	2.10	2.20	2.30	83	87	91
E	2.90	3.00	3.10	114	118	122
E1	1.10	1.20	1.30	86	87	91
L	0.45	0.55	0.65	18	22	26
e	0.50 BASIC			20 BASIC		
e1	2.00 BASIC			80 BASIC		

# Package Specification (WLCSP)

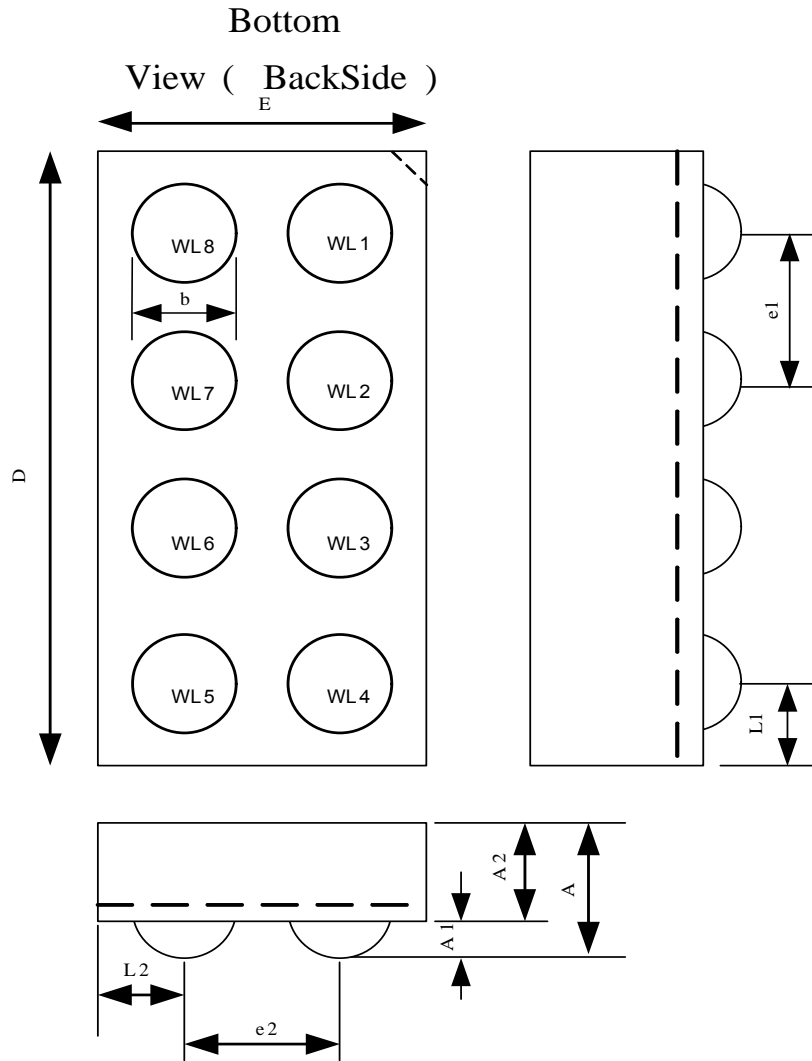

SYMBOL	DIMENSION (mm)		
	MIN.	NOM.	MAX.
A	0.445	<b>0.50</b>	0.555
A1	0.17	0.20	0.23
A2	0.275	0.30	0.325
b	0.24	0.26	0.28
D	1.54	<b>1.59</b>	1.64
E	0.74	<b>0.79</b>	0.84
e1		0.40	
e2		0.40	
L1	0.170	0.195	0.220
L2	0.170	0.195	0.220



The products listed herein are designed for ordinary electronic applications, such as electrical appliances, audio-visual equipment, communications devices and so on. Hence, it is advisable that the devices should not be used in medical instruments, surgical implants, aerospace machinery, nuclear power control systems, disaster/crime-prevention equipment and the like. Misusing those products may directly or indirectly endanger human life, or cause injury and property loss.

Silicon Touch Technology, Inc. will not take any responsibilities regarding the misuse of the products mentioned above. Anyone who purchases any products described herein with the above-mentioned intention or with such misused applications should accept full responsibility and indemnify. Silicon Touch Technology, Inc. and its distributors and all their officers and employees shall defend jointly and severally against any and all claims and litigation and all damages, cost and expenses associated with such intention and manipulation.